

# Weber Carb Linkage, Synchronizers, and Anti-Vibration mounts

## TOOLS, AIR FLOW & SYNCHRONIZING

**STE synchronometer**, type SK for synchronizing multiple throttle body and carburetor installations. This is a true air flow meter which will provide very accurate balancing of individual runner systems. **STE-SK**



**STE synchronometer**, type BK for synchronizing carburetor installations where more than one cylinder is fed by the primary barrel. This is a true air flow meter which will permit a very high air flow, affecting mixture strength no more than an air cleaner at idle speeds. **STE-BK**



**ADAPTOR for DGV series carburetor**



**STE-40**

**ADAPTOR for DCOE series carburetor, 90 degrees.**



**STE-06**

## FLOAT LEVEL GAUGE

This marvellous instrument enables the user to check the float level on sidedraft carburetors without the inconvenience of removing the top cover and, in some instances, the fuel lines.

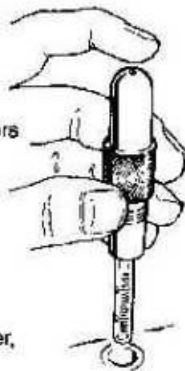

Simply remove the jet cover and a main jet stack, lower the glass tube into the float bowl, cover the air hole with your finger, lift out the tool and read the fuel level on the graduated scale.

**2600-1000**

## CARBURETOR SOFTMOUNT KITS

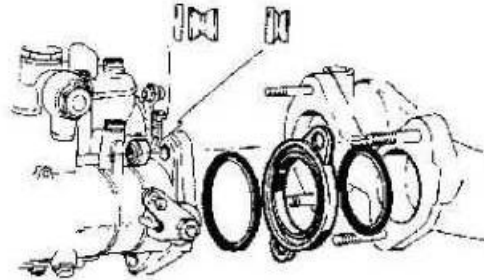

Weber 40 DCOE	<b>31993</b>
Weber 42, 45 DCOE	<b>31994</b>
Weber 48 DCOE	<b>31995</b>
Weber 50 DCO/sp	<b>32997</b>

**Soft mount O rings, 40-48mm**



Per set of 4  
**31998**

**Soft mount O rings, 50mm**

Per set of 4  
**31999**

**Grommet**

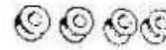

per set of 4  
**31988**

**Retainer, washer for grommet**



Per set of 4  
**31990**

## CARBURETOR MOUNTING STUDS & NUTS



DIN dimension

Stud, 5/16-18 x 5/16-24 x 1.375	<b>40937</b>
Stud, M8 x 1.25 x 20 T' body stud	<b>31800</b>
Stud, M8 x 1.25 x 46 softmount stud	<b>31802</b>
Nut, locking M8 x 1.25 set of 4	<b>32998</b>
Nut, locking 5/16-24 set of 4	<b>32999</b>

**Top-End Performance**

**818 764-1901**

**818 764-0155 fax**

**CENTER PULL LINKAGE (Pulls up)**  
 For Weber 40, 42, 45 DCOE. Interfaces with our  
 cables # 34129 and 34160.

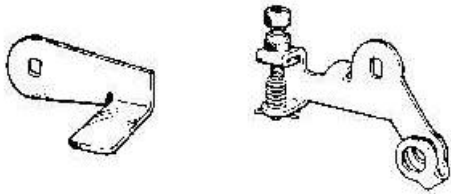

Drive lever **33038**  
 Slave lever **33039**

**CENTER PULL LINKAGE (Pulls down)**

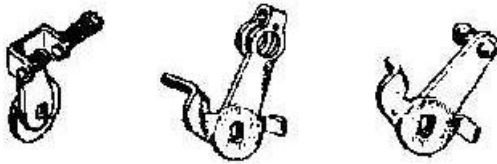

Drive lever with ball **45041.009**  
 Drive lever with cable hook **45048.007**  
 Slave lever with spring and plunger **45048.005**

**BRACKET**, cable mounting, with swivel.

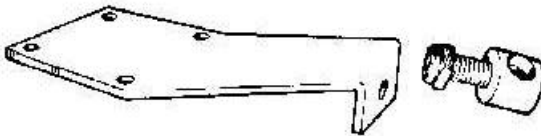

Mounts to bottom of DCOE carburetor. For use with  
 pull down, center pull linkage. **40930**

**BALL SOCKETS**

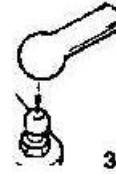

5/16 Socket, 10-32 r/h thread **31610**  
 5/16 Socket, 10-32 l/h thread **31611**

**BALL SCREW**



5/16" dia, with nut and washer **31584**

**THROTTLE LEVERS**

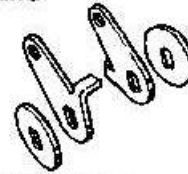

**31700** right  
**31701** left

For Weber DCOE Carburetors  
 View from air horns, forward toward engine, for left  
 and right.

**LEVER AND WHEEL** assembly  
 For DGV and DGAV Weber carburetors.

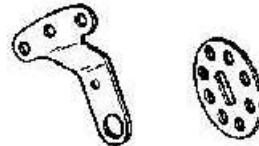

**31703**

**THROTTLE LEVERS** for Weber DGV and DGAV

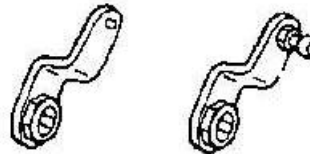

with #10 hole **31704**  
 with 5/16 ball **31705**

**Top-End Performance**  
**818 764-1901** **818 764-0155 fax**

**THROTTLE CABLE COMPONENTS**

**Cable swivel**

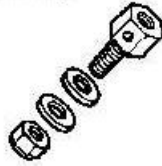

For 8mm cables  
For 6mm cables

31582  
31583

**Cable clamp**

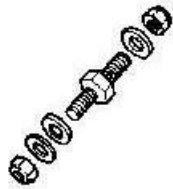

31600

**Trunnion, .375" Dia  
.250" Dia**



41037  
41038

**Cable adjuster  
M8 x 1.0 thread**



31807

**Firewall fitting  
Machined from 6061-T6**

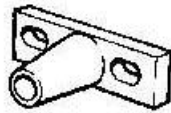

34159

**THROTTLE CABLE ASSEMBLY  
with trunnion**



Outer sleeve- 36"  
Inner wire 42"

34129

**THROTTLE CABLE ASSEMBLY**

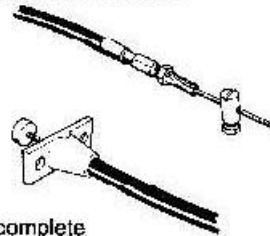

As 34129 but complete  
with firewall fitting  
and adjuster

34160

**THROTTLE CABLE ASSEMBLY**



Replacement cable for our DCOE  
conversion on Sprite/Midget  
and MGB

33034

**THROTTLE CABLE ASSEMBLY**

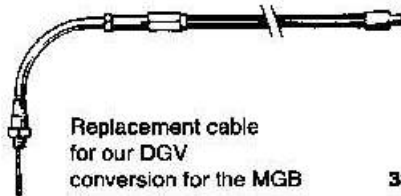

Replacement cable  
for our DGV  
conversion for the MGB

33035

**CHOKE CABLE**

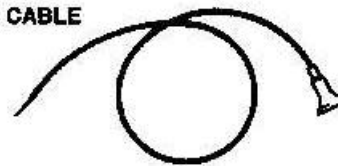

72" Woven wire with twist lock knob 40834

**Top-End Performance**  
818 764-1901 818 764-0155 fax

**LINKAGE SHAFT HARDWARE**

**CROSS**

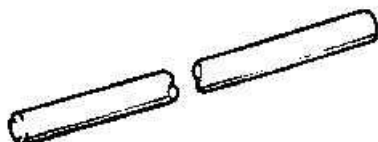

Ground stainless rod .375"

9"	35009
10"	35010
12"	35012
15"	35015
16"	35016
18"	35018
20"	35020
22"	35022

**SHAFT COLLAR**

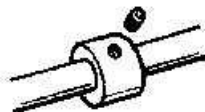

with set screw **31904**

**SHAFT RETURN SPRING AND LEVER**

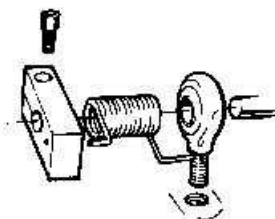

Right hand **31706**  
Left hand **31707**

**SHAFT BUSHINGS**

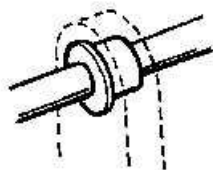

.250 ID **31606**  
.3125 ID **31605**  
.375 ID **31604**

**ADJUSTABLE LINKAGE RODS**

6061-T6 Hex bar with forged rod ends

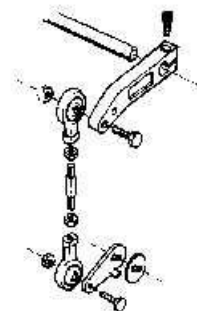

3.25"-4.25"	(83-108mm)	<b>34000</b>
3.75"-4.75"	(95-120mm)	<b>34001</b>
4.75"-5.75"	(120-148mm)	<b>34002</b>
5.5"-6.5"	(140-165mm)	<b>34003</b>
6.5"-7.5"	(165-190mm)	<b>34004</b>
7.5"-8.5"	(190-215mm)	<b>34005</b>
8.5"-9.5"	(215-240mm)	<b>34006</b>
9.5"-10.5"	(240-266mm)	<b>34007</b>
10.5"-11.5"	(266-293mm)	<b>34008</b>
11.5"-12.5"	(293-318mm)	<b>34009</b>

**CROSS SHAFT LEVERS**

Machined from 6061-T6 billet, for the ultimate in locks, strength and durability. Machined to fit our ground .375" shaft material.

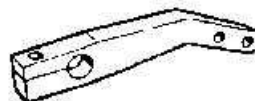

Cranked lever 2.5" **32000**

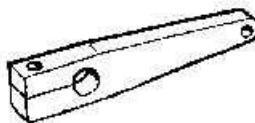

Straight lever, cast, 2.5" **32001**

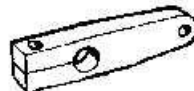

Straight lever 1.5" **32002**

**Top-End Performance**  
**818 764-1901      818 764-0155 fax**

**CARBURETOR MOUNTING GASKETS**

Weber DGV, DGAV, DGEV  
**32022**

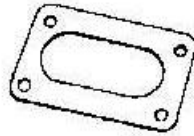

Weber DGV etc. air clnr to carb  
**32024**

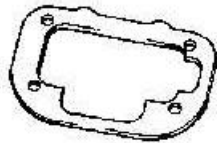

Weber DGV etc. .125" spacer  
**33014**

.250" spacer  
**33016**

.500" spacer  
**33017**



Weber DGAS .125" spacer  
**40932**

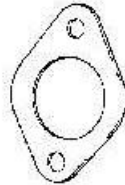

Weber DCOE 40mm **35040**  
 45mm **35045**  
 48mm **35048**

**MGB LINKAGE KIT**

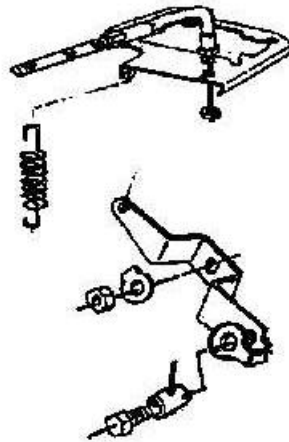

Update your Cannon or Plerce MGB down draft kit, with our superior linkage. Includes cable, top bracket, throttle lever and spring.  
**37727**

**UNIVERSAL LINKAGE KIT FOR DGV SERIES CARBURETORS**

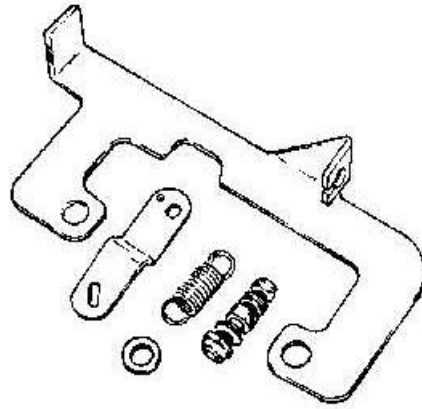

**31620**

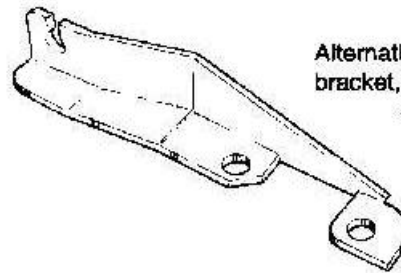

Alternative cable bracket, DGV  
**40108**

**HEATSHIELD, dual Weber carbs**

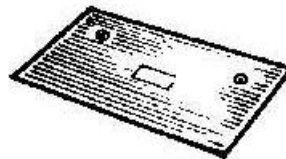

**25167**

**Top-End Performance**  
 818 764-1901      818 764-0155 fax

## CARBURETOR AND AIR CLEANER ADAPTORS

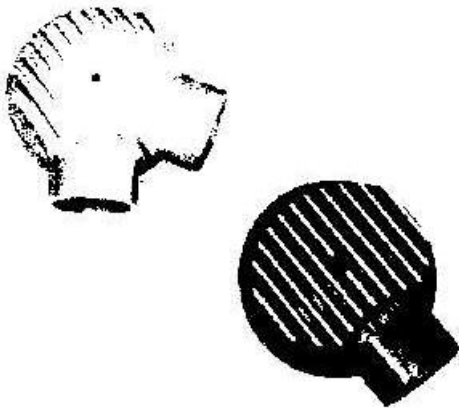
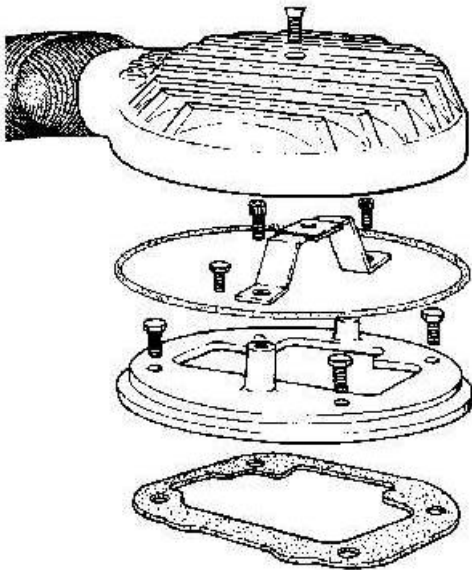

Bonnet kit for remote filter. Will fit DGV and DGAS type carburetors. Kit contains all the above parts, except hose, which is ordered separately.

Single snout kit	<b>0090</b>
Dual snout kit	<b>0091</b>
Wire reinforced silicone hose 2.5" ID.	
Order in 1 foot increments	<b>CAT 10</b>

## DOWNDRAFT CARBURETOR ADAPTORS

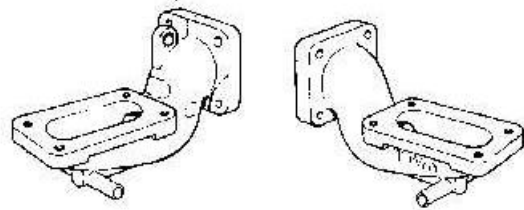

These adaptors permit the use of DGV series carburetors on some Zenith Stromberg and S U manifolds. They have provision for coolant plumbing. Complete with studs, nuts and gaskets.

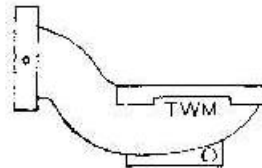

**8-0034** Vertical flange

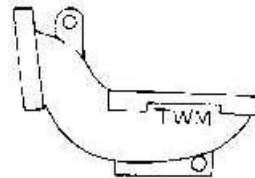

**8-0083**  
Flange at 10 degree

## CHOKE HOUSINGS for DGAV series CARBURETORS

TWM manufactured choke housings designed to replace the standard units on DGAV carburetors.

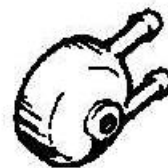

**32444.003**  
5/16 tubes

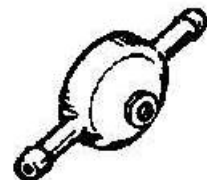

**32444.012**  
3/8 tubes

**Top-End Performance**  
**818 764-1901**      **818 764-0155 fax**

## ROD ENDS AND COMPONENTS

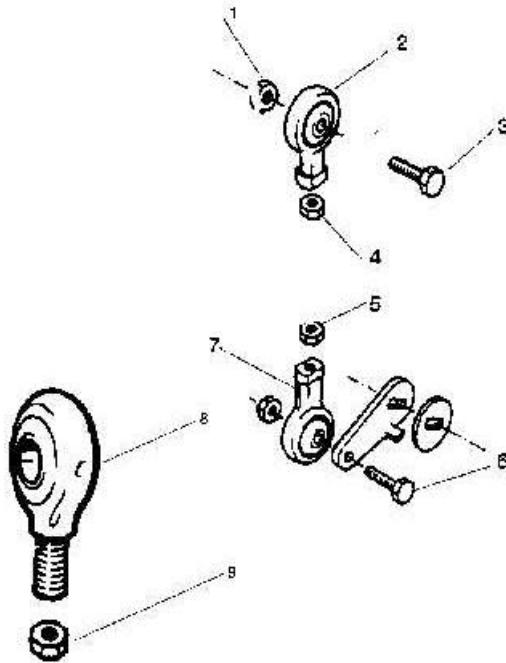

- |   |                 |
|---|-----------------|
| 1. Nyloc low profile nut, 10-32   | <b>31911</b>    |
| 2. Rod end 3/16 r/h thread, female  | <b>31608 -f</b> |
| Rod end 3/16 r/h thread, male   | <b>31608 -m</b> |
| 3. Screw, 10-32 x .750  | <b>31808</b>    |
| 4. Nut, jam 10-32 r/h   | <b>31909</b>    |
| 5. Nut, jam 10-32 left hand thread  | <b>31910</b>    |
| 6. Screw, 10-32 x .675  | <b>34105</b>    |
| 7. Rod end, 3/16 left hand thread, female                                 | <b>31609 -f</b> |
| Rod end, 3/16 left hand thread, male                                      | <b>31609 -m</b> |
| 8. Rod end 3/8 r/h thread, female   | <b>34106 -f</b> |
| Rod end 3/8 r/h thread, male  | <b>34106 -m</b> |
| 9. Nut, jam, 3/8-24   | <b>33060</b>    |
| 10. Stepped stud, adapts 3/8-24 female rod end to 5/16-24 manifold thread | <b>34106</b>    |

## RELINK KITS for DCOE CARBURETORS

You can convert the linkage on that old Cannon, Lynx or Warnford manifold to the same spec as the race quality parts supplied with TWM manifolds. With their CNC machined, 6061-T6 billet levers and forged rod ends these kits are available for twin and triple DCOE carburetors.

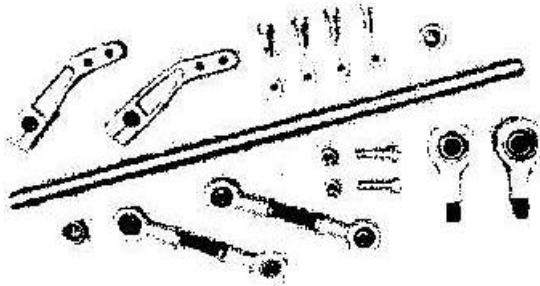

- |                   |              |
|-------------------|--------------|
| Dual relink kit   | <b>31624</b> |
| Triple relink kit | <b>31625</b> |

## FUEL UNIONS

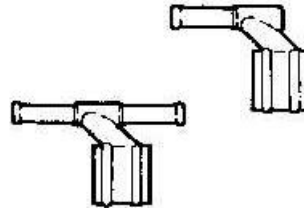

- |                           |              |
|---------------------------|--------------|
| Weber DCOE, single outlet | <b>32012</b> |
| Weber DCOE, dual outlet   | <b>32013</b> |

**Top-End Performance**

**818 764-1901**

**818 764-0155 fax**