

CUSTOM INTERCOOLER SPECIFICATION FAX FORM

Intercooler manifolds can be custom fabricated to your specifications.

See the examples below of how to mark up and add dimensions on the cores shown to the left below.

Provide overall maximum space available, including thickness and size of inlet and outlet tubes

Name: _____
Telephone: _____
Fax: _____

Engine Size: _____
Boost Pressure: _____
Max. RPM _____
Max. HP _____

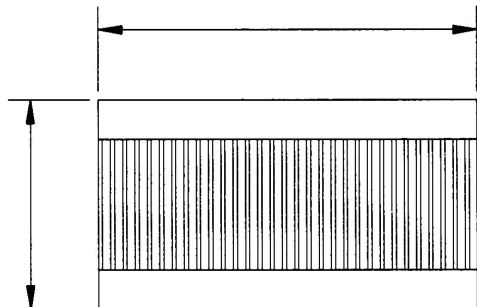
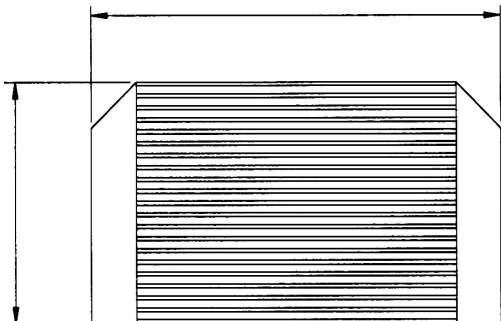
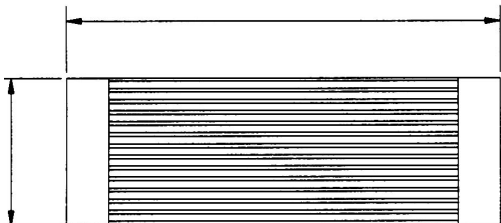

EXAMPLE #1

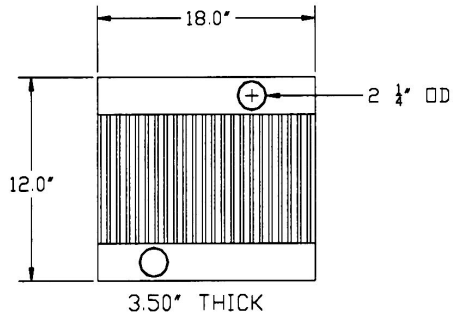

EXAMPLE #2

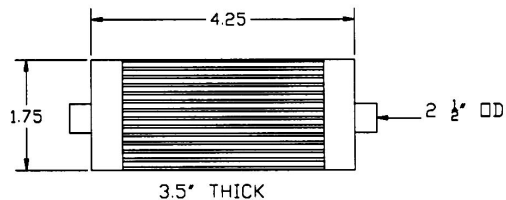

NOTES: _____

Fax to 818 764-0155